

Storage

Greenlee storage boxes protect the tools you depend on for your livelihood. From our smallest storage chests to the large field office, our products are built as tough as the trade. With Greenlee's patented, dual-recessed lock enclosures, you know you'll keep thieves out. And the newest feature on all of Greenlee's storage boxes are the redesigned ergonomic handles – just another way Greenlee is helping to make your job easier.

Feature Product



Chests

page
322

page
323

Slant-Top Boxes

Feature Product



Feature Product



Flat-Top Boxes

page
324

page
325

Utility Cabinets

Feature Product



Chests



3048



2448



2472

- Patented, recessed and concealed lock protectors for maximum security against drilling and cutting lock. (Model 1332 one lock protector only.)
- Enhanced lid bolster for added support and durability.
- Finger-groove lid handle for easy opening.
- Convenient storage tray on back wall for small items (except Model 1332).
- Steel support arms to hold lid in open position.
- Heavy-duty piano hinges with non-removable pin.
- Large, fold-down recessed handles for convenient lifting.
- Built-in 3-1/2" high skids with holes for easy caster installation.
- Patent pending.

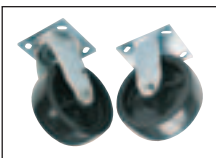
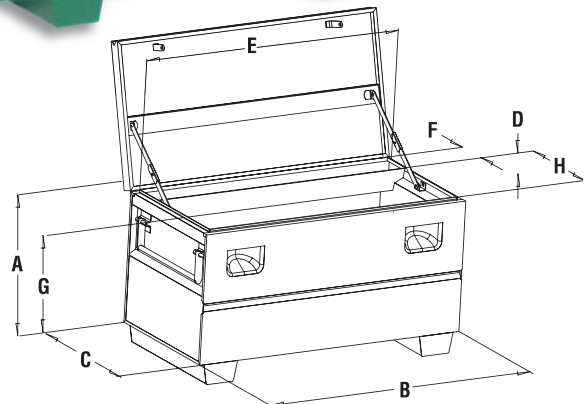

Optional casters available for increased mobility.

See page 330 for options

CAT. NO.	UPC NO.	CAPACITY FT ³	DIMENSIONS								WEIGHT	
			A	B	C	D	E	F	G	H	LBS.	kg
1332	38717	4.9	14"	32"	19"	—	29.5"	—	—	14.5"	83	37.6
1636	38718	6.7	17"	36"	19"	4"	33.5"	4"	10.5"	10.5"	99	44.9
2142	31651	9.7	20"	42"	20"	4"	39.5"	4"	13.5"	11.5"	113	51
2448	23273	16	24"	48"	24"	4"	45.5"	4"	17.5"	15.5"	156	66
2460	23363	20	24"	60"	24"	4"	57.5"	4"	17.5"	15.5"	182	83
3048	23362	25	30"	48"	30"	4"	45.5"	4"	23.5"	21.5"	183	83
2472	07483	24	24"	72"	24"	4"	69.5"	4"	17.5"	15.5"	185	84

Slant-Top Boxes



3660



2260



3648



Hinged Lower Shelf

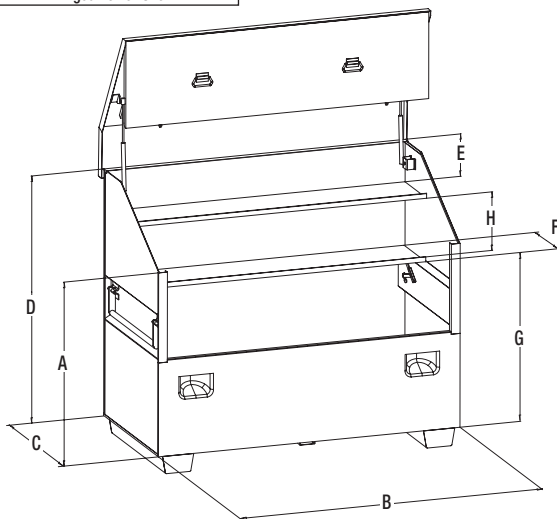

- Large capacity storage with traditional slant-top design.
- Recessed and concealed lock protectors provide maximum security against drilling and cutting locks.
- Channel reinforcements on lid lock side panels into lid for added security when closed.
- Hinged lower shelf enables storage of larger items.
- Hemmed (reinforced) high-strength shelves.
- Continuous, non-removable hinge pins help prevent theft.
- Strategically located, easily accessible, durable gas-shocks provide for ease in opening lid (except Model 2260).
- Angled 3-1/2" high support skids.
- Angled handle recess prevents pinch points.
- Features two reinforced steel shelves with large lip to prevent items from rolling off (Model 2260, one shelf only).
- Double-hinged cover on Models 3648 and 3660 folds up and out of the way.
- Model 2260 comes with lid support to form waist-high, flat work area.
- Patent pending.

CAT. NO.	UPC NO.	CAPACITY FT ³	DIMENSIONS								WEIGHT	
			A	B	C	D	E	F	G	H	LBS.	kg
2260	23270	32	22"	60"	32"	36"	12"	12"	21"	—	228	103
3648	23276	34	36"	48"	30"	48"	5"	12"	27"	11"	273	124
3660	23196	44	36"	60"	30"	48"	5"	12"	27"	11"	282	128

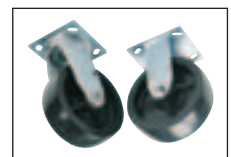

Optional casters available for increased mobility.
See page 330 for options

Flat-Top Boxes



3360



4848



4860



Hinged Lower Shelf



4872



4872R

- Flat-top design provides more storage capacity for tall, bulky items, plus a large work surface for jobsite plans.
- Recessed and concealed lock protector inhibits forced entry and corrosion to lock.
- Channel reinforcements on lid lock-side panels into lid for added security when closed.
- Hinged lower shelf allows for easy storage of larger objects (except Model 3360).
- Angled handle recess prevents pinch points.
- Hemmed (reinforced) high-strength shelves.
- Continuous, non-removable hinge pins help prevent theft.
- Side-wall storage (except Model 3360).
- Strategically located, easily accessible, durable gas springs provide for ease in opening lid.
- Double hinge cover folds up and out of the way.
- Angled 3-1/2" high support skids.
- Load ramp for storage of larger, heavier items (Model 4872R only).
- Patent pending.

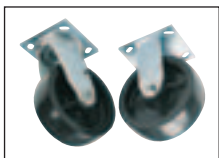
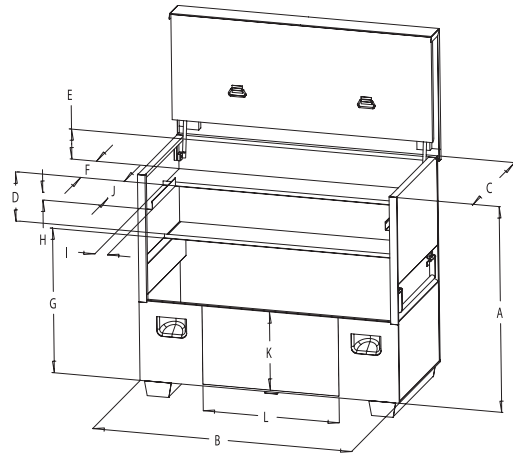

Optional casters available for increased mobility. See page 330 for options

CAT. NO.	UPC NO.	CAPACITY FT ³	DIMENSIONS											WEIGHT LBS. kg			
			A	B	C	D	E	F	G	H	I	J	K		L		
3360	38719	34.5	33"	60"	30"	—	12.5"	12"	20"	—	—	—	—	—	—	256	116
4848	35043	40	48"	48"	30"	11"	7"	12"	27"	2"	3"	17"	—	—	—	292	132
4860	35057	50	48"	60"	30"	11"	7"	12"	27"	2"	3"	17"	—	—	—	305	138
4872	07487	60	48"	72"	30"	11"	7"	12"	27"	2"	3"	17"	—	—	—	360	163
4872R	07488	60	48"	72"	30"	11"	7"	12"	27"	2"	3"	17"	18"	45"	—	375	170

Utility Cabinets

2-DOOR UTILITY CABINET



5660L

HALF-STORAGE/HALF CABINET BOX



5660LH

4-DOOR UTILITY CABINET



5760

2-DOOR, 30" DEPTH STORAGE CABINET



5760TD

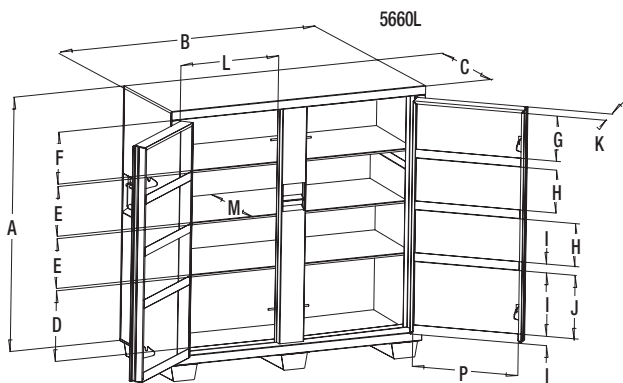

- Recessed and concealed lock protector inhibits forced entry and corrosion to lock.
- Flush-mounted doors.
- Finger-groove door handles.
- Front-door storage. (Rear-door storage also available on Model 5760 only.)
- Hemmed (reinforced) high-strength shelves.
- Large, lower storage areas for bigger items.
- Continuous, non-removable hinge pins to prevent theft.
- Angled handle recess to prevent pinch points.
- Three 3-1/2" high support skids. (Not available on Model 3448.)
- Weather-resistant design.
- Open storage for shovels, picks, brooms and other long-handled tools. (Model 5660LH only.)
- Patent pending.

Optional casters available for increased mobility. See page 330 for options

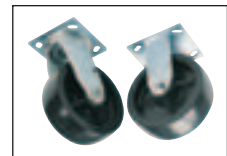

CAT. NO.	UPC NO.	CAPACITY FT ³	DIMENSIONS														WEIGHT			
			A	B	C	D	E	F	G	H	I	J	K	L	M	N	O	P	LBS.	kg
5660L	38659	46	56"	60"	24"	15"	10.5"	11.5"	10"	10"	2"	14"	3"	23.5"	20.5"	—	24"	—	401	182
5660LH	07486	46	56"	60"	24"	15"	10.5"	11.5"	10"	10"	2"	14"	3"	23.5"	20.5"	50.5"	—	24"	408	185
5760	38722	58.3	56"	60"	30"	15"	10.5"	11.5"	10"	10"	2"	14"	3"	23.5"	23.5"	—	24"	—	437	198
5760TD	07969	59.3	56"	60"	30"	15"	10.5"	11.5"	10"	10"	2"	14"	3"	23.5"	26.5"	—	24"	—	467	212

Parts/Fittings Cabinet

2072

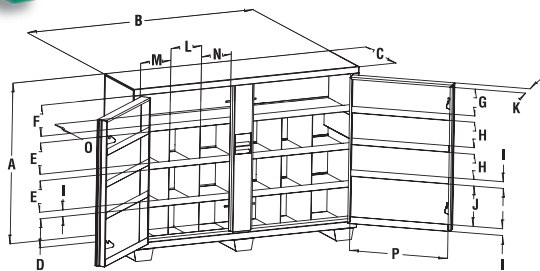
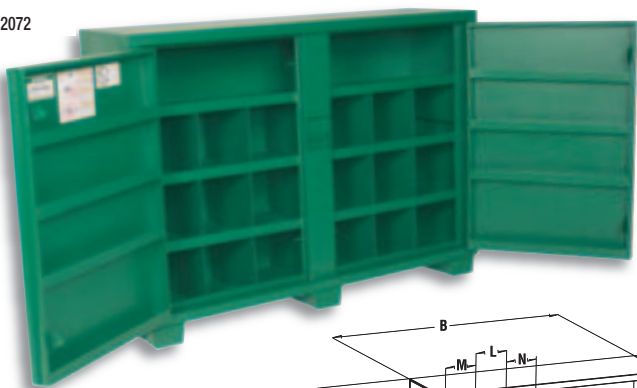

- Recessed and concealed lock protector inhibits forced entry and corrosion to lock.
- Flush-mounted doors.
- Finger-groove door handles.
- Front-door storage.
- Hemmed (reinforced) high-strength shelves.
- Continuous, non-removable hinge pins to prevent theft.
- Angled handle recess to prevent pinch points.
- Three 3-1/2" high support skids.
- Eighteen (18) individual separate parts storage compartments.
- Weather-resistant design.

CAT. NO.	UPC NO.	CAPACITY FT ³	DIMENSIONS														WEIGHT LBS. kg			
			A	B	C	D	E	F	G	H	I	J	K	L	M	N		O	P	
2072	07484	40	48"	72"	20"	8.5"	9"	9"	8"	7.5"	2"	12"	3"	10"	10"	9.5"	16.5"	29	406	184

Mesh Cabinet



5060MESH

- High-visibility mesh screen on three (3) sides.
- Forty-eight (48) smaller, individual compartments, enabling storage of smaller tools and accessories.
- 1/2" conduit support tunnels for top storage (conduit not included).
- Platform for shovels, picks, brooms and other long-handle tools.
- Sturdy handle for mobility.
- Supplied with (2) swivel casters and (2) rigid 4" (102 mm) casters for easy mobility (Model 695).

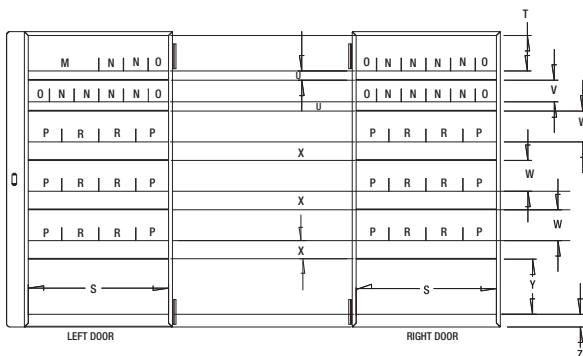
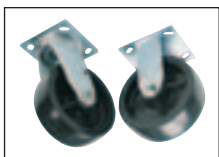
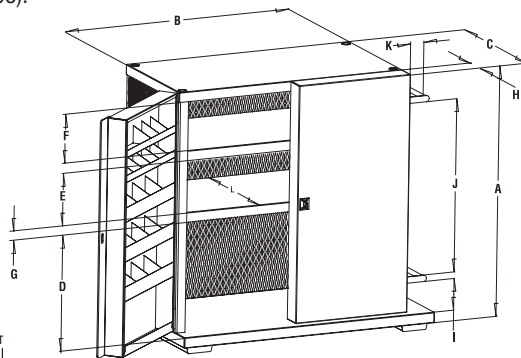

CAT. NO.	UPC NO.	CAPACITY FT ³	DIMENSIONS																				WEIGHT LBS. kg						
			A	B	C	D	E	F	G	H	I	J	K	L	M	N	O	P	R	S	T	U		V	W	X	Y	Z	
5060MESH	04460	37.3	52"	48"	28"	22"	10.5"	10"	2"	4"	5"	35"	5.5"	23"	11.5"	4"	3"	5.5"	6"	23"	5.5"	1.5"	3.5"	5"	3"	9"	2"	401	182

Bi-Fold Cabinet



5860

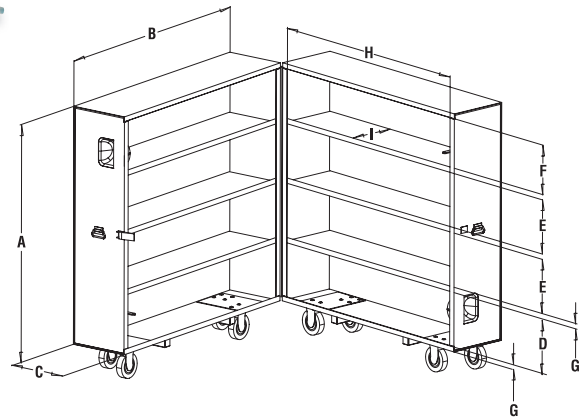

- Maximum storage capacity with minimum floor space requirements.
- Four individual 15" d. x 14-1/2" h. x 60" w. (381 x 368 x 1524 mm) storage compartments on each side.
- Reinforced steel shelves welded in place for added strength and durability.
- All shelves feature large front lip to keep small items from rolling off.
- Each bi-fold section is mounted on four casters for easy opening and closing.
- Six (6) swivel and (2) rigid 6" (152 mm) casters included for easy mobility (Models 503 and 603).

CAT. NO.	UPC NO.	CAPACITY FT ³	DIMENSIONS									WEIGHT	
			A	B	C	D	E	F	G	H	I	LBS.	kg
5860	35068	60.4	58"	60"	30"	13"	13"	12"	1"	57"	14.5"	548	249

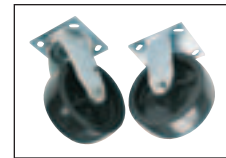

Cabinet/Workbench

3448

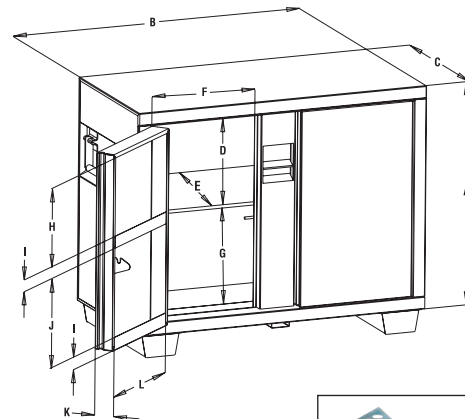

- Recessed and concealed lock protector inhibits forced entry and corrosion to lock.
- Flush-mounted doors.
- Finger-groove door handles.
- Front-door storage.
- Hemmed (reinforced) high-strength shelves.
- Large, lower storage areas for bigger items.
- Continuous, non-removable hinge pins to prevent theft.
- Angled handle recess to prevent pinch points.
- Weather-resistant design.

CAT. NO.	UPC NO.	CAPACITY FT ³	DIMENSIONS											WEIGHT		
			A	B	C	D	E	F	G	H	I	J	K	L	LBS.	kg
3448	38720	22.5	34"	48"	24"	13.5"	20.5"	17.5"	15"	12.5"	2"	14"	3"	17"	201	91.2

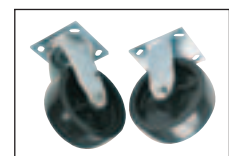

Optional casters available for increased mobility.
See page 330 for options

Field Office



8060 DLX

(Tools sold separately)



Tamper-proof lock protectors (for upper and lower doors).

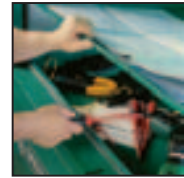

New, slanted work surface with lockable, concealed storage area.



Door grooves provide a gripping surface for convenient opening.



Top door opens with a gas spring and is supported by a locking arm.

- New, slanted work surface with lockable, concealed storage area.
- Concealed lock protectors protect locks from drilling and cutting.
- Weather stripping for maximum protection against bad weather and jobsite dust.
- Lid with heavy-duty gas spring and a locking arm for ease of opening and safety.
- Shelving throughout, for organizing and storing jobsite tools and supplies.
- Grooved front doors for ease of opening and storage compartment access.
- Continuous, non-removable pin hinges.
- Overlapping corners, rolled edges, and strategically placed reinforcements for added strength.

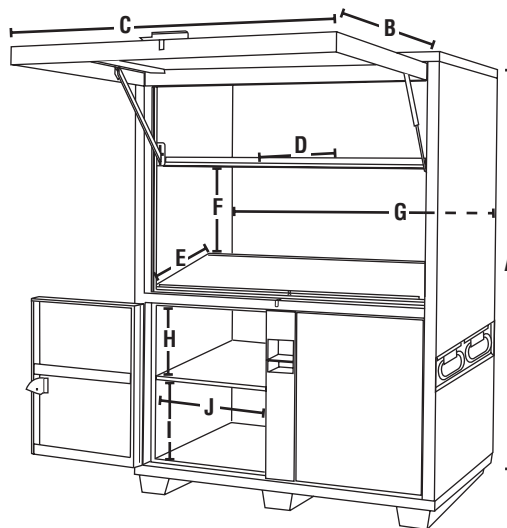

Optional casters available for increased mobility. See page 330 for options

CAT. NO.	UPC NO.	CAPACITY		DIMENSIONS								WEIGHT			
		FT ³		A	B	C	D	E	F	G	H	I	J	LBS.	kg
8060 DLX	04719	116.5		80"	60"	42"	20.6"	26.8"	19.2"	58.8"	14"	15.5"	24"	632	286

Mobile Workbench



- Tough composition board work surface on top with built-in chain vise and telescoping wrench stop.
- Removable self-stored shelf enables storage of larger items.
- Supplied with (2) locking swivel casters and (2) rigid 6" (152 mm) casters for easy mobility (Model 703).
- Recessed and concealed lock protector inhibits forced entry and corrosion to lock.
- Flush-mounted doors.
- Finger-groove door handles.
- Front door storage.
- Hemmed (reinforced) high-strength shelves.
- Large lower storage areas for bigger items.
- Continuous, non-removable hinge pins to prevent theft.
- Angled handle recess to prevent pinch points.
- Patent pending.

3548

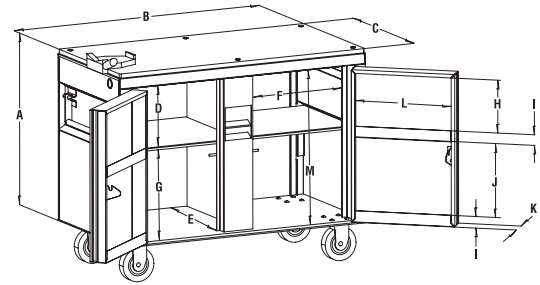

CAT. NO.	UPC NO.	CAPACITY FT ³	DIMENSIONS											WEIGHT			
			A	B	C	D	E	F	G	H	I	J	K	L	M	LBS.	kg
3548	31229	23	30"	48"	24"	11"	20.5"	17.5"	15"	9.5"	2"	13"	3"	17"	27"	257	118

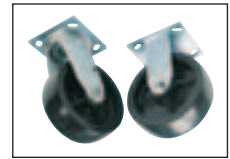

Welder's Boxes

1230



1531



- Protects small tools and supplies. Single lock hasp for use with padlock.
- Compact side handles for easy portability.
- Heavy-duty hinges, plus chain connector to hold lid in open position.

CAT. NO.	UPC NO.	CAPACITY FT ³	DIMENSIONS			WEIGHT	
			HEIGHT	WIDTH	DEPTH	LBS.	kg
1230	31510	3.3	12"	30"	16"	48	21.8
1531	23274	4.5	15"	31"	18"	51	23.1

Casters



- Caster bolt pattern 2-7/8" x 3-1/4".
- Polyolefin-injected molded hard rubber casters: stain-resistant, chemical-resistant, and non-marking.
- Recommend #1 and #5 Masterlock padlocks or equivalent.

CAT. NO.	UPC NO.	DESCRIPTION	WHEEL		CAPACITY		SHIP WEIGHT	
			DIA. IN.	TREAD IN.				
			(mm)	(mm)	LBS.	kg	LBS.	kg
503*	28044	4 Swivel	6	2	2000	907	22	10
			(152)	(51)				
603*	23405	2 Rigid, 2 Swivel	6	2	2000	907	20	9
			(152)	(51)				
703†	08420	2 Rigid, 2 Locking Swivel	6	2	2000	907	20	9
			(152)	(51)				
803†	08414	4 Locking Swivel	6	2	2000	907	22	10
			(152)	(51)				
666*	15341	2 Rigid, 2 Swivel	4	2	1600	726	13	6
			(102)	(51)				
695*	30239	2 Rigid, 2 Swivel	4	1-1/2	1500	680	10	5
			(102)	(38.1)				
694*	35113	4 Swivel	4	2	1600	726	13	6
			(102)	(51)				

*Each caster set includes (16) 3/8-16 x 1" self-threading mounting screws.

†Each caster set includes (16) 3/8-16 x 1" carriage bolts; (16) 3/8-16 hex nuts; (16) 3/8 lockwashers.

CASTER SELECTION CHART

STORAGE BOX CAT. NO.	CASTER CAT NO.						
	503	603	703	803	666	695	694
1332	✓	✓			✓	✓	✓
1636	✓	✓			✓	✓	✓
2142	✓	✓			✓	✓	✓
2448	✓	✓			✓	✓	✓
2460	✓	✓			✓	✓	✓
3048	✓	✓			✓	✓	✓
2472	✓	✓			✓	✓	✓
1230							
1531							
5060MESH	✓	✓			✓	✓	✓
3360	✓	✓			✓	✓	✓
4848	✓	✓			✓	✓	✓
4860	✓	✓			✓	✓	✓
4872	✓	✓			✓	✓	✓
4872R	✓	✓			✓	✓	✓
2260	✓	✓			✓	✓	✓
3648	✓	✓			✓	✓	✓
3660	✓	✓			✓	✓	✓
3448	✓	✓			✓	✓	✓
5660L	✓	✓			✓	✓	✓
5660LH	✓	✓			✓	✓	✓
5760	✓	✓			✓	✓	✓
5760TD	✓	✓			✓	✓	✓
5860				Included	Included		
3548				Included	✓		
8060DLX						✓	✓

Replacement Parts

REPLACEMENT PARTS

CAT. NO.	UPC NO.	DESCRIPTION
06291	06291	Box Caster Bolt Set (16-Bolt Kit)
08426	08426	Box Caster Bolt Set 16-Bolt Kit (3548, 5860 only)
35438	35438	Lid Support Kit – (R) and (L) Locking Arms (1332, 1636, 2142)
27472	27472	Lid Support – (L) Side (2448, 3048, 2460, 2472, 2260)
27471	27471	Lid Support – (R) Side (2448, 3048, 2460, 2472, 2260)
08428	08428	10 mm Gas Spring Ball Stud Replacement Kit (all Slant/Flat-Tops)
53950	53950	Gas Springs for 2260
53904	53904	Gas Springs for 3360, 4848 and 4860 Storage Boxes
53951	53951	Gas Springs for 3648 and 3660
04339	04339	Latch Repair Kit (5860)
54997	54997	Latch (5860)
54998	54998	Strike (5860)
55124	55124	Latch Threaded Rod (5860)
08427	08427	13 mm Gas Spring Ball Stud Replacement Kit (8060 DLX)
08404	08404	Replacement Gas Spring Kit – Shock and (2) Clips (8060 DLX)
01886	01886	Replacement Gas Spring Kit for 4872